



Morphology and photovoltaic architectural integration: students' explorations on the 'fifth façade' in Lima's multi-family projects

Morfología e integración arquitectónica fotovoltaica: exploraciones estudiantiles sobre la 'quinta fachada' en multifamiliares de Lima

RICHARD VALDIVIA-SISNIEGAS 
Universidad Ricardo Palma, Perú
richard.valdivia@urp.edu.pe

DIEGO MANCILLA-BRAVO 
Universidad Ricardo Palma, Perú
diego.mancilla@urp.edu.pe

VIVIAN CHICHIPE-MONDRAGÓN 
Universidad Ricardo Palma, Perú
201820723@urp.edu.pe

PAOLA CHICCHE-MAMANI 
Universidad Ricardo Palma, Perú
201820731@urp.edu.pe

AYLIN VÍLCHEZ-DOMÍNGUEZ 
Universidad Ricardo Palma, Perú
aylin.vilchez@urp.edu.pe

RESUMEN La integración estética de sistemas solares en multifamiliares es un desafío todavía inédito en países latinoamericanos. Sesenta y cinco proyectos desarrollados por estudiantes de arquitectura en Lima (Perú) fueron considerados para establecer criterios de composición mediante clasificación tipológica a nivel de disposición de los sistemas fotovoltaicos, composición volumétrica, relación con las fachadas y los espacios inferiores. Los resultados demuestran múltiples posibilidades. Sin embargo, existen limitaciones para entender esta integración cuando se trata de la inclinación de los techos, así como la coherencia y la disposición geométrica en las configuraciones irregulares obtenidas. Tratándose de multifamiliares y debiendo lidiar con aspectos técnicos, se requiere mayor énfasis en la comprensión de la organización interior y sus implicancias con los sistemas solares. Una investigación previa relacionada a la cuantificación de la incidencia solar ha sido ya publicada, sin embargo, investigaciones para mayores evaluaciones estéticas en multifamiliares de media densidad podrían realizarse a futuro.

PALABRAS CLAVE estética, transición energética, fotovoltaicos, integración arquitectónica, multifamiliar

ABSTRACT The aesthetic integration of solar systems with multi-family buildings remains rare in Latin American countries. This article considers sixty-five projects by architecture students in Lima (Peru) to establish compositional criteria using typological classifications of the solar system layout on the roofs, volumetric composition, and their relationship with façades and lower spaces. The results show a wide range of variables that must be resolved. However, there are limitations to understanding this integration when dealing with the inclination of roofs as well as the coherence and geometric arrangement in irregular configurations. More emphasis is required on understanding the interior organisation and its implications for solar systems when designing multi-family houses. Previous research on the quantification of solar incidence has already been published; however, more research for further aesthetic assessments in medium-density multi-family dwellings could be carried out in the future.

KEYWORDS aesthetics, energy transition, photovoltaics, architectural integration, multi-family

Received: 24/11/2023
Revised: 20/04/2024
Accepted: 30/04/2024
Published: 31/07/2024



Cómo citar este artículo/How to cite this article: Valdivia-Sisniegas, R., Mancilla-Bravo, D., Chichipe-Mondragón, V., Chicche-Mamani, P. & Vilchez-Domínguez, A. (2024). Morphology and photovoltaic architectural integration: students' explorations on the 'fifth façade' in Lima's multi-family projects. *Estoa. Revista de la Facultad de Arquitectura y Urbanismo de la Universidad de Cuenca*, 13(26), 149-164. <https://doi.org/10.18537/est.v013.n026.a09>



Figure 1: a) Models and façade study of the multifamily housing project in Leidesdorfgasse, Vienna (2012), Achitekturbüro Reinberg ZT GmbH. b) Vauban solar village (1998-2006). a) Architekturbüro Reinberg ZT GmbH, 2024. b) Rolfdisch SolarArkitektur, 2024

1. Introduction

The inclusion of photovoltaic cells in multi-family houses is still limited despite the evolution of energy regulations in some countries. However, the simultaneous ongoing crises (such as the uncertain economy and climate change) motivate immediate responses from actors leading to social innovation (Gurrutxaga Abad & Galarraga Ezponda, 2019), in the hope that structural changes can take place in the future. As these changes may take too long, climate change adaptation and mitigation initiatives can be created immediately. Student architecture projects can serve as seeds for social innovation by simulating new forms of cities, buildings, and ways of life, thereby fostering a migration towards more sustainable and resilient patterns.

Energy transition needs a decentralised and sustainable model that transcends the substitution of conventional energy with renewables. It must change the model of management and ownership of the electricity system, migrating from a classic model where a few companies control the generation and distribution of electricity to a decentralised, democratic and efficient model (Bermejo, 2013). To achieve this, energy must be generated on-site by means of 'prosumers' (persons who produce what they consume and even sell the surplus). According to Rios Villacorta (2016), this idea is still distant due to permissive regulations for fossil energy generators; meanwhile, the current division between the residential and energy sectors perpetuates inequalities in access to both essential services (Miranda Sara et al., 2022).

Although there are strong criticisms of apartment building models centred on profit, market speculation (Vargas-Villafuerte & Cuevas-Calderón, 2022) rapid construction and lack of quality (Hernandez Aja, 2007), as well as the development of blatantly unsustainable forms of urbanisation (Arellano Ramos, 2022); the

compact city, to be sustainable, requires multi-family housing to provide density. Therefore, more sustainable versions of this housing type are sought (providing energy efficiency, thermal comfort, and mixed uses), as well as solutions for urban sustainability (such as sustainable mobility, diversity, and tree planting). The work carried out by architecture students at the Faculty of Architecture and Urbanism of Ricardo Palma University (FAU-URP) in Lima (Peru) involves sustainable urban planning proposals, one of which is sustainable multi-family houses, including solar systems, among many other requirements. This article focuses on students' integration of photovoltaic systems in medium-density multi-family buildings as part of their educational competencies. It also takes into account other aspects that require resolution, such as interior organisation.

2. Methodology

The study focuses on the morphology created by adding PV systems to roofs. Bearing in mind that morphological aspects are vital in an architectural career, the aim is to survey PV integration in students' 4th-semester projects from 2019 to 2023 at FAU-URP, as well as their design criteria for multi-family buildings, defining the implications of the combination of PV systems and internal solutions. This is exploratory research, with observational and descriptive processes as part of a qualitative study. The projects were classified by analysing the solar form achieved according to a typological study of the volumetry, characterising the results by roof organisation, volumetry, façades and interiors. Although most solar projects are usually located in open environments, for these projects,



Figure 1: (c) BedZED village in South London (1997-2002). Bioregional (2024)

students selected plots located in urban blocks, which led to forms with blind walls on the internal perimeters, as usually happens in urban centres. For this reason, the irregular and disintegrated results differ from the compact and elongated solutions found in temperate and cold climates.

2.1. Solar form in multifamily projects

Although unnoticed solar integrations are possible, solutions exist where the photovoltaic integration is decisive in the resulting form. At the end of the 20th century, developed countries' policies in favour of environmental responsibility provided the opportunity for experimentation with active solar systems in residential projects. In Austria, the prolific architect Georg W. Reinberg stands out as a pioneer of solar, social and eco-friendly architecture (Wehle-Strzelecka, 2014). The low-density residential complex known as 'The Periscope House' in Sagedergasse (built 1997–1998) is relevant; this project, even with unfavourable conditions in terms of orientation and the height of the neighbourhood, achieved passive and active solar energy collection through imaginative use of the form of the buildings. The difficulty of integration is apparent in a more recent multi-family project in Leidesdorfgasse, Vienna (built 2012), as it is part of an urban block and, due to its orientation among other buildings, the solar collector is attached as a 'floating' element at the top (See Figure 1a).

A very well-known residential project is the Vauban district in Fribourg (1998-2006) with several multi-family houses (figure 1b), which, despite the lack of aesthetic regulations, the formal solutions turned out to be of a higher quality than expected (Bube, 2010). The blocks are elongated with four-storey duplexes, access balconies, and semi-detached houses. The guidelines were clear and provided interesting and diverse solutions. The 'Solar City' district in Linz (built 1995–2005) is another residential development with multi-family buildings; it has been criticised for its urban design, the layout of which creates little interaction with the streets because of its reduced and blind façades at the ends. (Schroepfer & Limin, 2023). Another case is the housing development BedZED in London (built 1999–2002), with three-storey blocks (Figure 1c), where solar energy was not a fundamental part of the design but is present in all buildings to recharge electric cars and insert energy into the grid. The solar component was reduced during construction due to its high cost at the time and initial strategies that reduced energy demand (Young, 2015). These three neighbourhoods result from their planned development, with strong initial links between the housing and energy sectors. They are compact, elongated forms with a planned orientation, optimising



Figure 2: Projects BAPV (a,b) and BIPV (c,d) a) BedZED, London, 1999-2002. b) ABC, Grenoble, 2020. c) Aktiv Stadhaus, Frankfurt, 2015. d) Apartment building, Zurich, 2022
a) Twinn (2003); b) France Villes & Territoires Durables (2023); c) Shūco (2023); d) Megasol (2021)

solar gains. Their urban result is organised and tends towards linearity of layout; although they do not provide greater diversity than parallel and elongated pavilions, which are difficult to replicate in many urban centres where multi-family development is individualised on available plots that are consolidated or renewed over time, sometimes as family undertakings.

2.2. Limitations of solar integration in multi-family houses

Planning multi-family buildings with PV systems is considered more desirable than retrofitting existing ones, and the decision to choose sustainable rooftop depends mainly on the economic incentives and policies in place to do so (Diamond & Webb, 2017; Reichelstein & Yorston, 2013). However, once the way has been paved, architectural problems must be addressed. In Australia, the City of Melbourne's Higher Density Residential Efficiency Solutions (Hi-RES) Project (City of Melbourne, 2012) identified physical constraints as a barrier to photovoltaic improvements in multi-family buildings due to: 1) the reduced rooftop area proportional to the number of apartments, given that energy demand in dense buildings requires more rooftop area, 2) competition and demand for rooftop space (shared uses), 3) rooftop facilities: air conditioning

units, antennas, elevator machine rooms, parapets and elements for safety harnesses reduce the available space and create shadows, 4) photovoltaic installation racks can penetrate waterproof coatings, and although non-penetrating ballast mountings are available, they involve greater weight and require assessment or structural reinforcement, increasing costs, 5) wiring could compromise external and internal coatings, creating filtering problems, 6) potential damage caused by installers, and 7) the height of buildings requires cranes for access and safety while installing PV units, increasing the costs (Roberts et al, 2019).

Although many apartments do not have access to the roof and there are also restrictions due to regulations (Valdivia-Sisniegas, 2021), since 2006 in the US, there are mechanisms to promote Community Solar Projects (CSPs) that consist of a distributed solar energy deployment model that allows customers to buy or lease part of a larger, off-site shared PV system (National Renewable Energy Laboratory, 2023). This mechanism facilitates access to solar energy for those unable to install PV systems on their property due to a lack of viable rooftop space, ownership, or capital. These problems often arise in multi-family dwellings as most tenants do not own the rooftop but have an unmet demand for renewables and their benefits (Hillyer & Wokutch, 2023).

2.3. Integration of pv systems into buildings

In tropical latitudes, the orientation of PV modules with low tilt angles allows for a wide range of variations (Chen et al., 2018; Serrano-Guerrero et al., 2021). The most common solution is introducing PV systems on the roofs, which requires minimal structural strength. However, three types of building integration have been identified worldwide:

2.3.1 Building applied/attached photovoltaics - BAPV

These appeared in the 1970s using aluminium structures and are connected in a building-mounted manner. They do not replace building components, can be mounted on a frame, and are only used for energy generation and shading the roof (Ghosh, 2020). In the BedZED project in London, PV panels are attached to building volumetry and combined with gardens and ducts (Figure 2a), while in the ABC (Autonomous Building for Citizens) project (Grenoble), their form is notably different from the buildings, achieving a forced but forceful idea (Figure 2b).

2.3.2. Building integrated photovoltaics - BIPV

These have been used since the 1990s when energy policies and subsidies promoted the commercialisation of domestic PV products (Shukla et al., 2016). They not only produce electricity but are also part of the construction. They are considered integrated as their removal compromises the functionality of the building envelope and the conceptual design of the building itself (Basnet, 2012). They are designed following specific construction requirements to form or replace construction components (Kuhn et al., 2021). BIPVs are embedded in conventional building elements (roofs, windows or facades) as an energy source and to create a certain desirable appearance, but future technical support and costs depend on policies and a consistent market. The Aktiv Stadthaus in Frankfurt (Figure 2c) and an apartment building in Zurich (Figure 2d) are interesting examples.

BIPVs have great potential in building renovations to upgrade the building envelope to the current energy efficiency regulations, although, depending on the geometry, they may not be the most suitable for solar (Corti et al., 2020). Reports indicate that BIPV products account for only 2% of the world's installed PV systems, and 35% of these products become unavailable after a short time as manufacturers fail to maintain their business (Haghighi et al., 2021). There are points of debate due to cost, the technical complexity of installation and maintenance, and reduced efficiency when applied to façades with obstructions (by context or even the shape itself).

2.3.3. Architectural integration of photovoltaics - AIPV

Five levels have been identified for integrating solar systems into a structure's design (Kaan & Reijnga, 2004): 1) the panels are placed invisibly; 2) they are superimposed on the existing design; 3) the PV system adds value to the architectural design; 4) the PV system determines the architectural design; and 5) PV integration gives rise to new architectural concepts. Which level to aim for depends on the style of architecture. In multi-family housing projects, levels 1 to 3 can be considered, while institutional or innovative projects can try levels 4 or 5. (Valdivia-Sisniegas et al., 2023). Generally speaking, there is no single form of solar integration, and it is not possible to define absolutely the most appropriate (Zalamea-León & Quesada, 2017). Both BAPV and BIPV can be part of the AIPV, but in tropical latitudes, roofs are more important because most of the radiation comes from the zenith. Table 1 illustrates the categories mentioned above, with multi-family projects occupying a still limited spectrum of the larger scale of architectural integration.

2.4. Morphology and esthetics of PV systems in buildings

The formal integration of PV systems consists of an external surface parallel and coplanar to regular elements of the building: roofs or façades (Aguirre et al., 2018). Solar panel integration is not usually considered indispensable in design (Sánchez-Pantoja et al., 2018a), and many architects do not seem interested in photovoltaic integration, partly because of the absence of regulatory schemes to encourage its use and because the complexities involved in energy-related issues and technical requirements are perceived as limiting and cumbersome (Aksamija & Mallasi, 2010). This is even more the case at the training level, to the point that it is discarded as an aesthetic option. Furthermore, formal integration of PV systems is considered in only a small number of multi-family projects, as efficiency and cost remain more important (Awuku et al., 2021).

In many aesthetic approaches, it is possible to differentiate both the design elements of the panel itself (colour, shape, texture) and the design principles or composition in the building (variety, balance, rhythm, contrast, proportion). This can be applied to BAPV or BIPV cases, although the latter tend to be the most aesthetically studied. It is also known that searching for a better location for photovoltaic elements can lead to interesting architectural expressions, influencing the form of the building as a consequence of their application, so the indirect impact is significant (Marchwiński, 2023). Apparently, there is more influence when increasing the deviation of the tilt angle from the horizontal axis, but for buildings in tropical latitudes, it is limited, although cleaning and rainwater drainage lead to steeper panel slopes (15° to 20°) and even more for solar thermal (25° to 35°).

AIPV (Architectural Integration of Photovoltaics)







PV Integration	1 placed invisibly	2 superimposed on the existing	3 Addition for value to the image	4 architectural image determined	5 new architectural concepts
BAP Building applied/attached photovoltaics	 Avalon Bay Dogpatch Apartment San Francisco, 2017 a	 BedZED (Londres) 1999-2002 b	 Vauban (Friburgo) 1998-2006 c	 ABC – Autonomous Building for Citizens (Grenoble) 2020 d	
BIP Building integration photovoltaics	 Maison Climat (Biel) 2022 e	 Apartment building (Zurich) 2021 f	 Aktiv Stadhaus apartments (Frankfurt) 2015 g		

Table 1: Multi-family projects in relation to PV integration. a) Sunlight and power (2023); b) Twinn (2003); c) Arthus-Bertrand (1999); d) France Villes & Territoires Durables (2023); e) Schweizer Bau Dokumentation (2023); f) Megasol (2021); g) Shüco (2023)

Some researchers refer to viewer perception and visual impact on the landscape (Sánchez-Pantoja, et al., 2018b), and indicate other issues related to 1) pattern and texture at the surface level as an influential factor in the aesthetic evaluation (surface complexity), as well as different levels of texture; and 2) fractality or fractal dimension, taking into account that a fractal is a visual image of certain features repeated at many different scales (contour complexity), and it has been related as the 'form'.

Research on visual impact level criteria and policy take into account geometry, among others (materiality, the modular pattern of the PV system, visibility and context sensitivity) (Munari Probst & Roecker, 2019). In this case, three levels of coherence of the 'geometric system' are established, taking into account the size of the collector field, its shape and its position in relation to its shape and its position in relation to the building.

The performance of shapes in terms of typical roof designs has also been comparatively explored through simulations (flat, shed, gable, hipped, and butterfly roofs) at a latitude of 35° south (Li et al., 2020). Research has been carried out in the equatorial region on existing multi-family buildings, analysing the use of BIPV and BAPV technologies for different levels of architectural integration in a case study of a residential block with apartments (Flores-Chafra et al., 2020).

2.5. Design process methodology

The structures chosen for the projects are located in low and medium-density zones, considering that a large proportion of multi-family houses proceed from vertical growth in a single plot. Each student selected a plot defined by the urban layout of the zone so that all the projects differed in orientation.

The plots can be occupied with a built-up area of up to 65%, which is the legal limit for multi-family buildings in Peru. The entrance level must include a neighbourhood shop/store close to the street, with the possibility of locating apartments at the backside. The buildings are medium-density (six floors) and must be arranged in blocks to create internal courtyards. The fronts have not been set back to integrate the buildings with the streets better, as well as to optimise the open area for natural ventilation and daylight at the rear. An aerial view shows irregular shapes with extremities and open areas. The building occupancy patterns result in from nine to 22 apartments per project, with distribution plans from three to six dwellings by level and from one to four shops/stores at the entrance level.

As an experimental process, the resulting ratio of potential solar systems to apartments and shops has been described in a previous article (Valdivia-Sisniegas et al., 2023). An average of four (± 1) panels per property is possible, which, depending on electricity consumption, can supply 50% of energy needs or even more in Lima. An average of up to 41,49% of the roof surface is required for the solar panels, and 10% of this area should be thermal panels to heat water (for a four-person dwelling). Conventional photovoltaic and thermal panels up to 2m² were chosen and can be arranged in any direction to generate surfaces integrated into the geometry.

The only technical requirements were: 1) orientation between the northeast and northwest ranges (NE – N – NW), which have been shown to be consistent in solar incidence, and 2) inclination; as Lima is located at latitude 12° south, tilt angles between 10° and 20° were possible in photovoltaic systems without significant energy losses. As part of the design process, a shadow analysis was done to detect and reduce shadows between the arrays. Projects were guided to improve solar incidence. On the other hand, the tilt angles of hot water collectors, as indicated in the Peruvian Technical Building Standard EM080, must be equivalent to the latitude of the site plus 10°; in the case of Lima, this is 12° + 10° = 22°, but it is possible to increment the tilt angles between 25° to 35° for the thermosiphon effect. Practical experiments between 20° and 45° showed no significant losses, with 25 minutes of difference to reach the same temperature (Grupo Sumac Inti, 2020). The union of thermal and photovoltaic systems was encouraged in the formal explorations, allowing for concave and convex rooftop morphology. Only geometrical aspects have been taken into account in this study, not texture and colour characteristics.

3. Results

3.1. Morphology determined by roof plans

Photovoltaics requires the deployment of arrays, which can be positioned in different ways. Four types have been identified in the projects: one-panel linear arrays, large planar arrays, small planar arrays, and mixed arrays. Many solutions depended on their integration into the structure after its internal organisation. In Figure 3, the grey colour represents photovoltaic surfaces, and the dark one represents thermal solar panel surfaces.

Many solutions (36,9%) were based on single-panel linear arrays due to the simplicity of accommodating them. This configuration was followed by mixed array solutions (29,23%), while large planar arrays were less commonly used (15,38%). Mixed configurations tend to generate a disorganised image, whereas, in the case of single-panel linear arrays, the configuration creates uniform patterns on flat roofs. Linearly reproduced single-panel configurations generate integration by similarity in both PV and thermal systems on flat roofs (16,92%). In a few cases (9,23%), the panels in large planar arrays are deployed in a dispersed manner.

For solar systems grouped in multi-row arrays, the volumetric and spatial influence can be much greater, providing the possibility of spatially 'shaping' the interior. Of the various groupings, these are most likely to overhang the street or courtyard (23,08%). 'H' and 'I' floor plan typologies, typical in multi-family buildings on small plots, are suitable for ordered

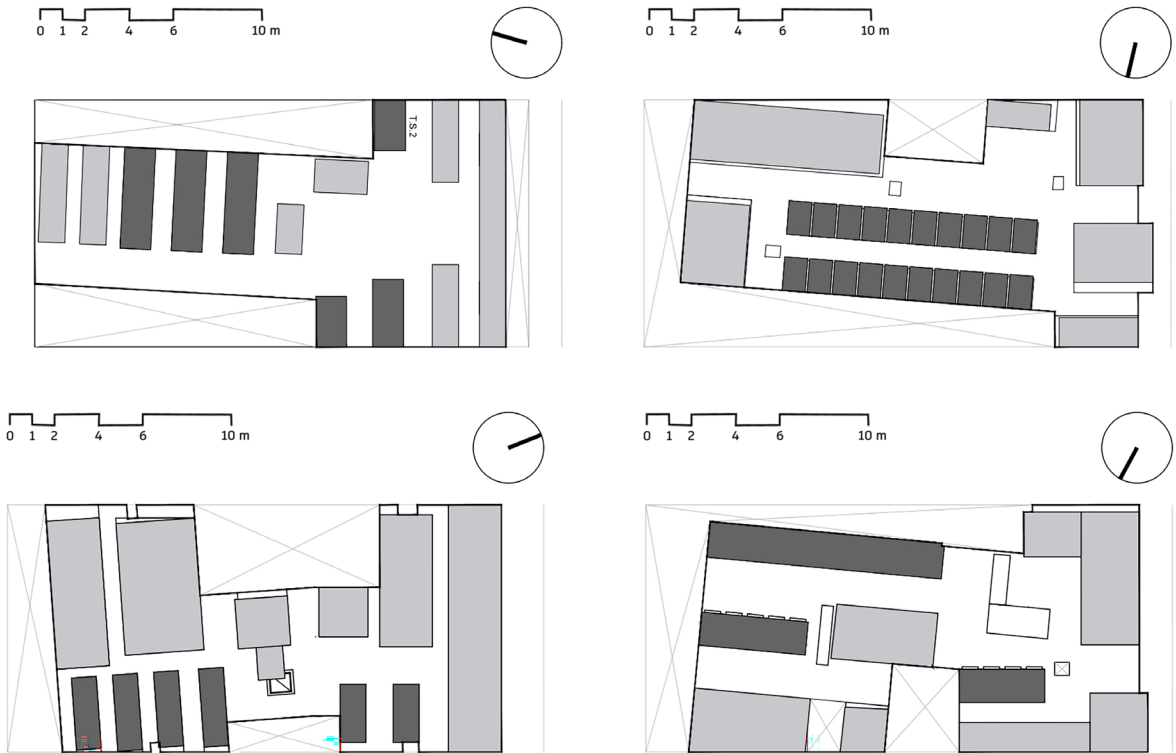

Figure 3: Classification according to the grouping on the roof a) single-panel linear arrays, b) large planar arrays, c) small planar arrays, d) mixed arrays
 Prepared by the authors on the basis of FAU-URP, Taller 9, 4th semester student's projects (2019-2023)

linear configuration formats (18,46%). In a third of the projects (35,38%), the PV arrays influence the walls of the spaces below, while in other cases, they have been superimposed without considering the possibility of integration with the underlying spaces. Some projects (18,46%) located many ventilation ducts in a scattered manner, necessitating mixed-type configurations (linear arrays with large planar arrays) of different sizes. In a few cases (12,31%), the ducts were dispersed due to an irregular volumetric layout. Table 2 presents these results.

3.2. Morphology determined by volumetric composition

The volumetric composition has been influenced by the interior organisation, as in the previous stage of the project. A smooth volumetric rotation of the structure was required as a formal exercise in most compositions with the added benefit of optimising the solar incidence to the north. The best understanding of junctions is achieved through modelling, both real and virtual, although the latter could limit the young students in formal manipulation. Slightly overhanging the solar surfaces lightens the volume, creating an impression of pitched roofs. As Figure 4 shows, there are three types of volumetric approaches.

In some cases (24,62%), the panels needed to be integrated into irregular shapes, which made the design of the arrays complicated and created residual spaces that were not integrated into the design. Considering that panels must be aligned perpendicular to the edges of the volumes for better coplanar integration, the alignment between panels and volumetry sometimes lacked clarity, specifically in the volumetric twists (18,46%). Apparently, there were limitations in the use of the three-dimensional software and the solutions created during plan and section studies. In many projects (60%), the volumetric twists were clearly integrated with the volumes despite the complexities of the plots. In some projects, the separation of the solar PV arrays was too small (26,15%), making maintenance and access to the roof difficult and even affecting solar incidence, reducing solar gain among the panels.

In a few cases (9,23%), concave and convex roofs were created by combining thermal and photovoltaic panels, which required a high level of understanding to link them to interior spaces to take advantage of these shape conditions. Some projects resorted to the 'H' and 'I' plan configuration (18,46%), a typology widely used in narrow plots. In a small portion (13,85%), overhanging panels alleviated the 'static cap' effect of volumes, creating more available roof area. Projects creating a sawtooth shape aligned with the façade on the rooftops

(38,46%) create an interesting, complimentary quality in the design as long as they are proportioned according to the length of the façade. However, they are often perceived as strange when the sawtooth shape evokes industrial architecture. Figure 5 shows the results of the student's projects.

3.3. Morphology determined by façades

The joints between photovoltaic and thermal systems on exterior façades provide an opportunity for conspicuous solar expression in the urban environment. Various walls and void options can be part of the composition by designing either aligned or segmented protruding volumes. Sawtooth façades provide rhythm, façades with interior slope overhangs provide hierarchy by raising the façade's height on the street, and façades with exterior slope overhangs culminate the projection of the volume (Figure 6).

Integration with the façade has been considered in many projects (53,85%), either with a sawtooth profile or as overhanging surfaces, both on the interior or exterior of the volume. In some projects (29,23%), the

panels are only slightly overhanging, and they are not used as a formal effect to improve the façade's design and extend it towards the street or courtyards. In a few cases, solar surfaces that slightly overhang the interior courtyards have been proposed (6,15%).

Most of the projects (75,38%) have few window surfaces, and these are of similar dimensions. The design of openings can be improved to highlight interior spaces, whether private (bedrooms) or public (living or dining rooms). Square-proportioned windows are more commonly used than horizontal ones (41,54%). There is a clear differentiation between openings on the entrance level (mainly used for shops) and those in the upper levels for dwellings (72,31%), creating different configurations.

The most obvious effect of integrating the photovoltaic panels into the façade is the sawtooth profile, and the contour generated by the façade can facilitate the window alignments (29,23%). Creating balconies, either by adding or subtracting volume from the façades according to the inclination of the solar panels (Figure 7), makes a striking contribution to solar integration (20%).

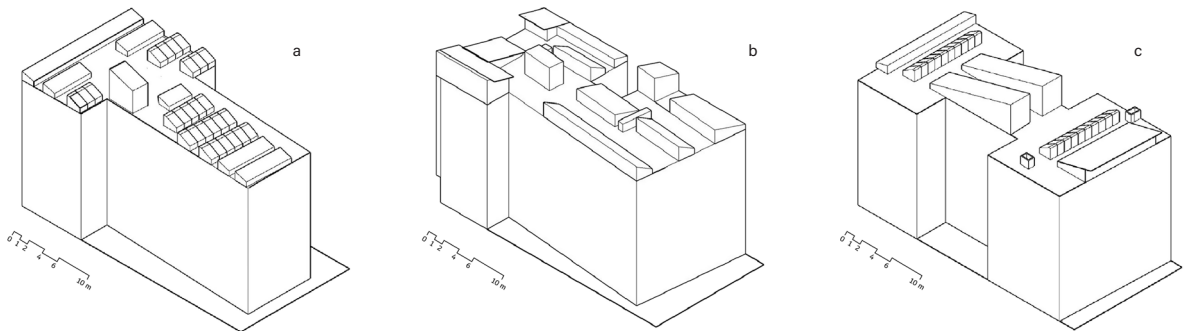

Figure 4: Classification according volumetric composition. a) Linear arrays, b) Mixed arrays, c) Large arrays. Prepared by the authors on the basis of FAU-URP, Taller 9, 4th semester student's projects (2019-2023)

Morphology at roof plans											
Type of solution	Graphical visualization										Percentage
	5	10	15	20	25	30	35	40	45	50	%
single-panel linear arrays	[Bar extending to 36.92]										36,92
mixed arrays solutions	[Bar extending to 29.23]										29,23
large planar arrays	[Bar extending to 15.38]										15,38
similar PV and thermal in flat roofs	[Bar extending to 16.92]										16,92
planar arrays in a dispersed way	[Bar extending to 9.23]										9,23
street or courtyards overhangs	[Bar extending to 23.08]										23,08
'H'/I' floor plan with linear arrays	[Bar extending to 18.46]										18,46
spaces below aligned to pv arrays	[Bar extending to 35.38]										35,38
without integration to interior	[Bar extending to 18.46]										18,46
dispersed ducts in an irregular layout	[Bar extending to 12.31]										12,31

Table 2: Solutions determined by roof plans. Prepared by the authors on the basis of FAU-URP, Taller 9, 4th semester student's projects (2019-2023)



Figure 5: Volumetric compositions designed with large planar arrays. Urban context was also modified with sustainable urban criteria
Prepared by the authors on the basis of FAU-URP, Taller 9, 4th semester student's projects (2019-2023)

3.4. Morphology created in indoors spaces

As observed in Figure 8, although the interior spaces are consequences of the architectural program organisation, the rooms on top levels associated with sloping roofs allow diverse spatial configurations, as well as daylight and ventilation. The *teatina* shape or skylights offer enormous possibilities to integrate thermal panels in combination with south-facing openings and a north-facing roof with chamfered planes and a steep pitch.

Many projects had difficulties linking the interior space with the upper photovoltaic solution; however, in the successful cases (50,77%), a well-achieved spatiality can be appreciated, as seen in Figure 9. The sawtooth shape with large arrays facilitates the integration of interior spaces by achieving dimensions similar to those of the interior (36,92%). A few projects included gable roofs (4,62%), with adequate spatial integration influencing the façade design. Lighting opportunities have been considered in a few cases (4,62%) by means of skylights or clerestories to integrate solar energy, either for photovoltaic or thermal use. In some projects (10,77%), balconies on the top levels overlooking the street or courtyards offer great potential for overhanging panels. Some projects with balconies used panels sloped either upwards or downwards at the edge of the façade, overhanging the balconies on the top floor (23,08%).

4. Discussion and conclusions

The projects successfully integrate PV arrays in multi-family urban blocks, in many cases with remarkable coherence. During the exercises, the effort to understand the impact and repercussions of the interior organisation on the roofs was evident.

The design of roofs requires a precise distribution of planar arrays and obvious joints to consolidate geometric order and coherence. Large planar arrays favour an orderly perception, enable the coherence of forms, integrate with interior spaces, and can overhang courtyard or street façades to create more area. In addition, these allow for elaborate geometric and volumetric development in the façade and courtyards. Single-row configurations create distribution patterns with a noticeable rhythm and similarity, but their geometric or spatial integration is limited, although they can be placed on the façade's surface as overhangs. In general, technical installations (especially ventilation ducts) have to be dealt with; for this reason, it is advisable to confine them to where they do not spoil the solar integration, such as in the contours of blind walls, or ultimately avoid them in the initial conception.

In volumetric aspects, rectangular PV panels often must be placed in irregular planes, and design time is required to manage the imperfections. On the other hand, rotating the volumes creates complexities in surfaces. The proportion of courtyards can help volumetric twists to optimise solar incidence and provide architectural differentiation in favour of formal variety despite the orthogonality of the plots. Close solar arrays are not appropriate, as they saturate perception and do not comply with the distances required for maintenance and better exposure to solar radiation.

■ *Teatina*: is a term used only on the Peruvian coast and refers to roof openings for zenithal ventilation and daylight. It is a rectangular opening made in the roof of a room, covered with a chamfered construction that ventilates one side. It gives good air intake, circulation, and daylight (Wieser, 2014).



Figure 5: Volumetric compositions designed with large planar arrays. Urban context was also modified with sustainable urban criteria
Prepared by the authors on the basis of FAU-URP, Taller 9, 4th semester student's projects (2019-2023)



Figure 6: Classification according to the influence on the façade. a) sawn façades b) façades with interior slope overhangs, c) exterior projected slope façades, c) façades with exterior slope overhangs. Prepared by the authors on the basis of FAU-URP, Taller 9, 4th semester student's projects (2019-2023)



Figure 7: a, b, c) Different types of façades with photovoltaic elements in clear communication with the street; d) Roof and façade in rendering model
Prepared by the authors on the basis of FAU-URP, Taller 9, 4th semester student's projects (2019-2023)

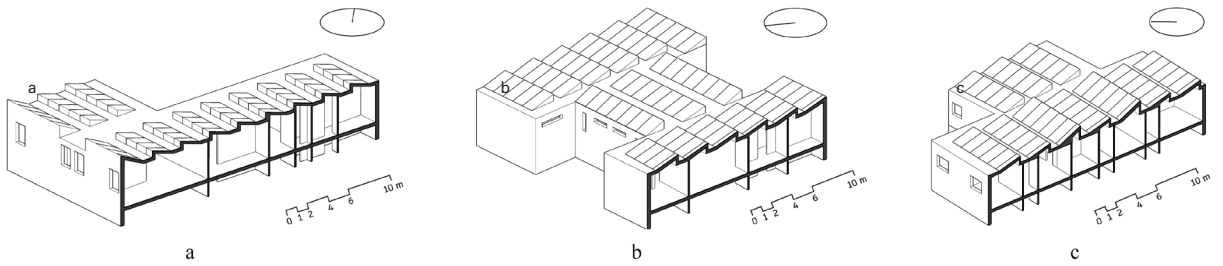

Figure 8: Integration with the interior depends on the joints of edges between walls and sloping ceilings. Types of linkage a) integrated b) semi-integrated c) non-integrated
Prepared by the authors on the basis of FAU-URP, Taller 9, 4th semester student's projects (2019-2023)

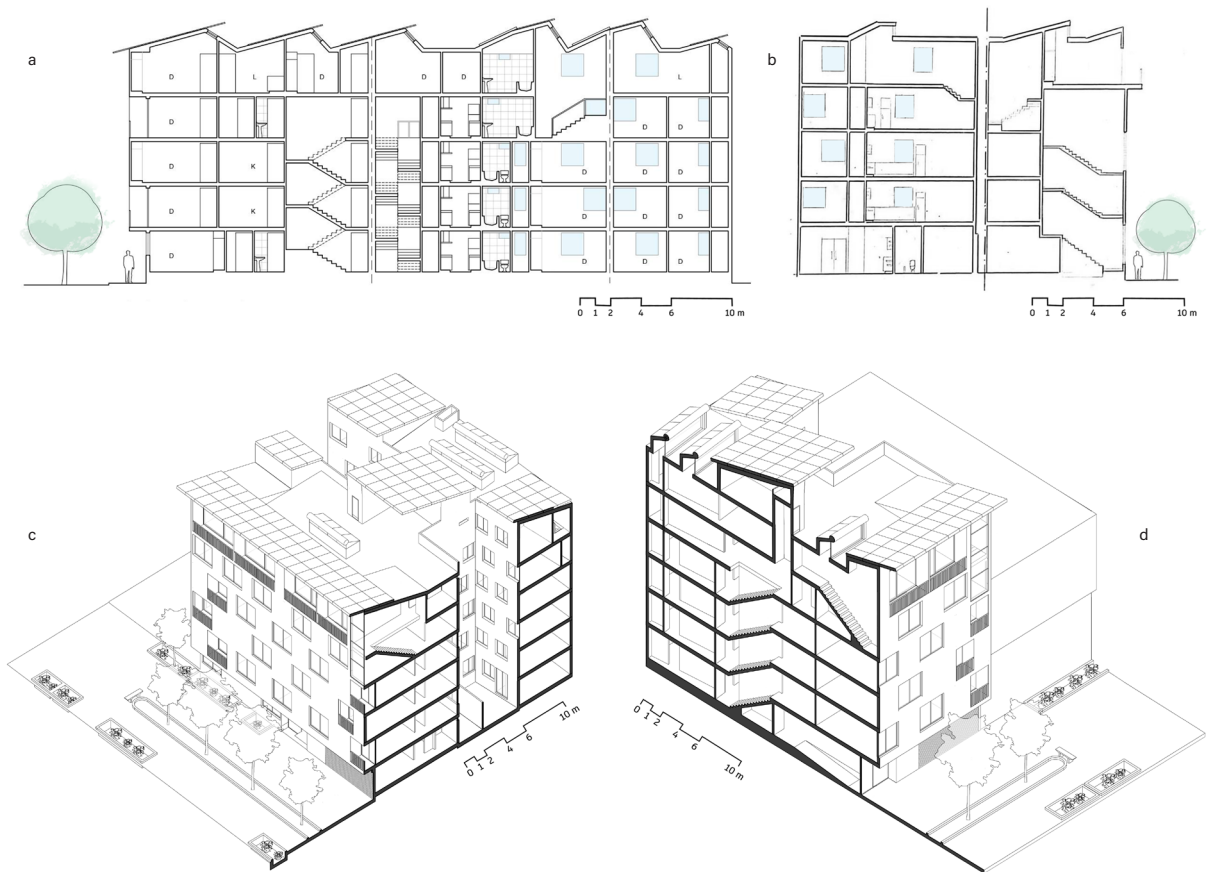

Figure 9: Diversity in interior spaces. a, b) Longitudinal and cross-sections; c, d) Axonometric cross-sections
Prepared by the authors on the basis of FAU-URP, Taller 9, 4th semester student's projects (2019-2023)

Many projects resolve the integration in irregular geometries, while H- and I-shape volumes can be solved depending on the orientation when the elongated parts are parallel to the east-west axis. Overhanging panels provide the visual appearance of lightness and inclined planes that slip past volumes or façades, as well as an additional area for solar gain. A sawtooth profile close to the façade can form overhangs or compositional lines for openings, although their treatment and proportion must not evoke the conventional image of industrial architecture. These arrays can form gable roof skylines; these cannot be very steep. Sawtooth façades convey volumetric solar integration in an evident manner, while geometries with concave and convex surfaces, thanks to mixing photovoltaic and thermal panels, are a still little explored opportunity to diversify aesthetic options in the configuration of roofs and even interior spaces.

At the educational level, designing the front and lateral façades requires more effort because the fifth façade has different functionality, and combining their relations is complex. When groupings of panels are placed behind the façade line, they are disconnected from a possible communication of the solar idea. At least one-third of the projects have only a minor influence on the façade, although misaligning windows allowed for some diversity. More than half achieve a direct effect on the façade by emphasising the solar idea (Figure 10), although in a lesser manner on courtyard façades. The exposed sawtooth facades express the solar idea to the surrounding context by creating finials as well as other technical co-benefits (a higher incidence of overhangs, shading on balconies, and cooling of the panels). NE-SE and NW-SW orientations are very adequate for sawtooth façades. Overhanging panels have been rarely used, but their contribution to the form by means of light finishes and sliding effects on balcony roofs lightens the volumes and communicates the solar idea.

The integration of interior spaces is the ultimate challenge, adding spatial complexity in flat environments by means of pitched roofs. While some integration has been achieved, time is needed for further exploration. Few projects use daylight by integrating clerestories or skylight windows into the upper flats, but in some notable cases, they have created internal spaces of varying heights. The opportunity for connected spaces such as mezzanines or attics could overcome strict regulations. Large planar arrays made integrating the interior with single or double-pitched roofs possible. Up to three balcony configurations have also been achieved, but they are strongly linked to the orientation.

Architectural integration of photovoltaic systems (AIPV) on roofs can involve panels either attached to (BAPV) or embedded in the envelope (BIPV). Although the general aesthetic trend favours BIPV despite the limitations encountered, BAPV is still an alternative for developing countries depending on their volumetric inclusion and integration strategies. The students' projects can be considered to have achieved the third level of architectural integration as they add value to the architectural image.

The typological classification demonstrates the diversity achieved in the projects, with an emphasis on roofs, which are usually simple flat surfaces in conventional multi-family architecture, particularly in environments like the Peruvian coast. In terms of photovoltaic integration, the top levels offer greater design challenges, demanding greater rigour when designing the fifth façade and improving spatial aspects close to the upper level. Students have approached the formal exploration of PV integration from intuition, demonstrating that it is possible to introduce it as a theme for an intermediate educational level, with flexibility and reducing extreme technical aspects usually addressed in energy issues.

Figure 10: Pedestrian views communicates better the solar idea at corners. Prepared by the authors on the basis of FAU-URP, Taller 9, 4th semester student's projects (2019-2023)



5. Recommendations

Designing multi-family houses with photovoltaic systems is a challenge, but it is currently possible to do so where policies and regulations are evolving in favour of sustainability. However, at the level of AIPV in multi-family buildings, it has been found that the more the geometries are resolved, the more interior organisation challenges are faced. Hence, a pedagogical orientation towards anticipating the impacts of the initial decisions is important, as well as the control and management of technical installations during the design. The orientation and inclination of the photovoltaic surfaces in buildings' top levels offer a field of continuous exploration, including spaces such as balconies, which generate remarkable communication with the exterior.

Characteristics such as the texture and colour of PV units can be analysed in further aesthetic research, considering a different approach when dealing with the roofs. Further explorations about connections to interior spaces and technical discussions for every specific project remain to be done.

6. Acknowledgements

To the students at 4th semester of Taller 9 section (2010-2023), FAU-URP.

Conflict of interests. The authors declare no conflict of interests.

© **Copyright:** Richard Valdivia-Sisniegas , Diego Mancilla-Bravo, Vivian Chichipe-Mondragón, Paola Chicche-Mamani and Aylin Vélchez-Domínguez, 2024.

© **Copyright of the edition:** *Estoa*, 2024.

7. Bibliographic references

- Aguirre, G. M., Maidana, A. E., Bellot, R. J., & Puig, S. E. (2018). *Los enfoques de la envolvente fotovoltaica en el proyecto de arquitectura*. [Paper presentation] X Congreso Regional de Tecnología en Arquitectura CRETA. La Plata, Argentina. http://sedici.unlp.edu.ar/bitstream/handle/10915/71357/Documento_completo.pdf-PDFA.pdf?sequence=1&isAllowed=y
- Aksamija, A., & Mallasi, Z. (2010). Building performance predictions: How Simulations Can Improve Design Decisions. *Perkins+Will Research Journal*, 2, 7-32.
- Arellano Ramos, B. (2022). *El urban sprawl. Un modelo de urbanización insostenible*. [Doctoral dissertation, Universidad Politécnica de Cataluña]. UPCommons. <https://upcommons.upc.edu/handle/2117/396560>
- Architekturbüro Reinberg ZT GmbH. (2024, May 22). *Vienna, Leidesdorfgasse: Residential units*. Architekturbüro Reinberg. <https://reinberg.net/en/projekt/vienna-leidesdorfgasse-residential-units/>
- Arthus-Bertrand, Y. (1999). *Earth from above*. Yann Arthus-Bertrand's Photos. <http://www.yannarthusbertrand2.org/collection/earth-from-above/>
- Awuku, S. A., Bennadji, A., Muhammad-Sukki, F., & Sellami, N. (2021). Myth or gold? The power of aesthetics in the adoption of building integrated photovoltaics (BIPVs). *Energy Nexus*, 4, 100021. <https://doi.org/10.1016/j.nexus.2021.100021>
- Basnet, A. (2012). *Architectural Integration of Photovoltaic and Solar Thermal Collector Systems into buildings*. [Master's thesis. Norges teknisk-naturvitenskapelige universitet, Fakultet for arkitektur og billedkunst, Institutt for byggekunst, historie og teknologi]. NTNU Open <https://ntnuopen.ntnu.no/ntnu-xmlui/handle/11250/231103>
- Bermejo, R. (2013, June 17). Ciudades poscarbono y transición energética. *Revista de Economía Crítica*, 2(16), 215-243. <https://revistaeconomiacritica.org/index.php/rec/article/view/332>
- Bioregional. (2024, May 22). *BedZED - the UK's first major sustainable community*. <https://www.bioregional.com/projects-and-services/case-studies/bedzed-the-uks-first-large-scale-eco-village>
- Bube, T. (2010, September). *The Vauban Quarter in Freiburg, Germany*. [Paper presentation]. In Foro Internacional de Vivienda Sustentable 2010. Mexico city. México. http://cijnwdb.plusenergiehaus.de/files/pdf/Foro_Internacional_de_Vivienda_Sustentable_2010.pdf
- Chen, X. M., Li, Y., Zhao, Z. G., Ma, T., & Wang, R. Z. (2018). General method to obtain recommended tilt and azimuth angles for photovoltaic systems worldwide. *Solar Energy*, 172, 46-57. <https://doi.org/10.1016/j.solener.2018.06.045>
- City of Melbourne. (2012). *Delivering sustainable solutions for apartments: final report for the higher density residential efficiency solutions (Hi-RES) project*. State Government Victoria. <https://www.melbourne.vic.gov.au/SiteCollectionDocuments/delivering-sustainable-solutions.pdf>
- Corti, P., Bonomo, P., Frontini, F., Macé, P., & Elina, B. (2020). *Building Integrated Photovoltaics: A practical handbook for solar buildings' stakeholders*. [Status Report 2020] SUPSI, University of Applied Sciences and Arts of Southern Switzerland.
- Dimond, K., & Webb, A. (2017). Sustainable roof selection: Environmental and contextual factors to be considered in choosing a vegetated roof or rooftop solar photovoltaic system. *Sustainable Cities and Society*, 35, 241-249. <http://dx.doi.org/10.1016/j.scs.2017.08.015>
- Flores-Chafla, P., Pesantez-Peñafiel, D., Zalamea-León, E. F., & Barragán-Escandón, E. A. (2020). Capacidad e integración fotovoltaica en edificios mixtos de mediana altura en la región ecuatorial andina. *ACE Architecture, City and Environment*, 15(45), 1-25. <http://dx.doi.org/10.5821/ace.15.45.9307>
- France Villes & Territories Durables. (2023). *ABC – Autonomous Building for Citizens*. <https://sustainablecitybyfrance.org/realisations/abc-autonomous-building-for-citizens-2/>

- Ghosh, A. (2020). Potential of building integrated and attached/applied photovoltaic (BIPV/BAPV) for adaptive less energy-hungry building's skin: A comprehensive review. *Journal of Cleaner Production*, 276. 123343. <https://doi.org/10.1016/j.jclepro.2020.123343>
- Grupo Sumac Inti. (2020, may 28). *La importancia de la inclinación de una terma solar* [video]. Facebook. <https://www.facebook.com/watch/?v=647213146009733>
- Gurrutxaga Abad, A., & Galaraga Ezponda, A. (2019). Recursos y dilemas de la innovación social: un concepto problemático. *RES. Revista Española de Sociología*, 28(1), 135-150. <http://dx.doi.org/10.22325/fes/res.2019.32>
- Haghighi, Z., Angali Dehnavi, M., Konstantinou, T., van den Dobbelen, A., & Klein, T. (2021). Architectural Photovoltaic Applications: Lessons Learnt and Perceptions from Architects. *Buildings*, 11(2), 62 <https://doi.org/10.3390/buildings11020062>
- Hernandez Aja, A. (2007, February). *Arquitectos inmobiliarios, elitistas, o sostenibles*. [Paper presentation] 2º Jornadas de Sostenibilidad, Arquitectura del siglo XXI: más allá de Kioto. Madrid, Spain.
- Hillyer, R. L., & Wokutch, A. S. (2023). *The Basics of Community Solar Projects and Their Application to Multifamily Projects*. Frost Brouwn Todd Attorneys. <https://frostbrowntodd.com/the-basics-of-community-solar-projects-and-their-application-to-multifamily-projects/>
- Kaan, H., & Reijenga, T. (2004). Photovoltaics in an architectural context. *Progress in Photovoltaics*, 12(6), 395-408. <https://doi.org/10.1002/pip.554>
- Kuhn, T. E., Erban, C., Heinrich, M., Eisenlohr, J., Ensslen, F., & Neuhaus, D. H. (2021). Review of technological design options for building integrated photovoltaics (BIPV). *Energy and Buildings*, 231, 110381. <https://doi.org/10.1016/j.enbuild.2020.110381>
- Li, H. X., Zhang, Y., Edwards, D., & Hosseini, M. R. (2020). Improving the energy production of roof-top solar PV systems through roof design. *Building Simulation*, 13(2), 475-487. <https://doi.org/10.1007/s12273-019-0585-6>
- Marchwiński, J. (2023, April). Architectural analysis of photovoltaic (PV) module applications on non-flat roofs. *Acta Scientiarum Polonorum. Architectura*, 22, 1-10 <https://doi.org/https://orcid.org/0000-0003-3897-3580>
- Megasol. (2021). *Leading Architecture Integrated Photovoltaics*. Megasol Energy Ltd. https://megasol.ch/wp-content/uploads/2022/03/Megasol_Integrated-Photovoltaics_BIPV-2203_Web.pdf
- Miranda Sara, L., Valdivia-Sisniegas, R. H., & Verdiére, M. (2022). Gobernanza energética y de la vivienda popular en Lima Metropolitana. In A. Castro, & M. I. Merino Gómez (Ed.), *Desafíos y perspectivas de la situación ambiental en el Perú* (pp. 441-463). Instituto de la Naturaleza, Tierra y Energía INTE-PUCP. <https://doi.org/10.18800/978-9972-674-30-3.022>
- Munari Probst, M. C., & Roecker, C. (2019). Criteria and policies to master the visual impact of solar systems in urban environments: The LESO-QSV method. *Solar Energy*, 184, 672-687. <https://doi.org/10.1016/j.solener.2019.03.031>
- National Renewable Energy Laboratory. (2023, January 17). *Community Solar*. U.S. Department of Energy. www.nrel.gov: <https://www.nrel.gov/state-local-tribal/community-solar.html>
- Reichelstein, S., & Yorston, M. (2013). The prospects for cost competitive solar PV power. *Energy Policy*, 55, 117-127. <https://doi.org/10.1016/j.enpol.2012.11.003>
- Rios Villacorta, A. (2016, June). *Estudio: Futuro de la Energía en Perú. Estrategias energéticas sostenibles*. International Rivers, Forum Solidaridad Perú.
- Roberts, M. B., Bruce, A., & MacGill, I. (2019). Opportunities and barriers for photovoltaics on multi-unit residential buildings: Reviewing the Australian experience. *Renewable and Sustainable Energy Reviews*, 104, 95-110. <https://doi.org/10.1016/j.rser.2018.12.013>
- Rolfdisch SolarArchitektur. (2024, May 22). *Projekte*. Rolf Disch Architekturbüro. <https://www.rolfdisch.de/projekte/>
- Sánchez-Pantoja, N., Vidal, R., & Pastor, M. C. (2018a). Aesthetic perception of photovoltaic integration within new proposals for ecological architecture. *Sustainable Cities and Society*, 39, 203-214. <https://doi.org/10.1016/j.scs.2018.02.027>
- Sánchez-Pantoja, N., Vidal, R., & Pastor, M. C. (2018b). Aesthetic impact of solar energy systems. *Renewable and Sustainable Energy Reviews*, 98, 227-238. <https://doi.org/10.1016/j.rser.2018.09.021>
- Schroepfer, T., & Limin, H. (2023). Emerging forms of sustainable urbanism: Case studies of Vauban Freiburg and Solarcity Linz. *Journal of Green Building*, 3(2), 65-76. <https://doi.org/10.3992/jgb.3.2.65>
- Shukla, A. K., Sudhakar, K., & Baredar, P. (2016). A comprehensive review on design of building integrated photovoltaic system. *Energy and Buildings*, 128, 99-110. <https://doi.org/10.1016/j.enbuild.2016.06.077>
- Schweizer Bau Dokumentation. (2023) "Maison Climat" Seelandweg <http://www.baudokumentation.ch/projekt/maison-climat-seelandweg/871376>
- Serrano-Guerrero, X., Cantos, E., Feijoo, J.-J., Barragán-Escandón, A., & Clairand, J.-M. (2021). Optimal Tilt and Orientation Angles in Fixed Flat Surfaces to Maximize the Capture of Solar Insolation: A Case Study in Ecuador. *Appl. Sci*, 11(10), 4546. <https://doi.org/10.3390/app11104546>
- Shúco. (2023). Active townhouse, Fráncfort - An innovative façade generates solar energy. <https://www.schueco.com/es/empresa/sostenibilidad/referencias/aktiv-stadthaus>
- Sunlightandpower. (2023). Avalon Bay Dogpatch apartments. <https://www.sunlightandpower.com/project/avalon-bay-dogpatch-apartments>
- Twinn, C. (2003). BedZED. *Arup Journal*, 38(1), 10-16. https://www.researchgate.net/profile/Chris-Twinn/publication/281980973_BedZED/links/56d95fc508aee73df6cf5096/BedZED.pdf
- Valdivia-Sisniegas, R. H. (2021). Aplanando la curva del consumo eléctrico con fotovoltaicos y hábitos ahorradores en un departamento en Lima (2017-2020). *Arquiteck*, 20, 42-55. <https://doi.org/10.47796/ra.2021i20.551>
- Valdivia-Sisniegas, R. H., Mancilla-Bravo, D. C., Chichipe-Mondragón, V. M., Chichipe-Mamani, P. B., & Vilchez-Domínguez, A. M. (2023). Potential of solar incidence in multi-family students' projects in Lima (Peru). *WIT Transactions on Ecology and the Environment*. 261, 101-113. <https://doi.org/10.2495/ESUS230091>
- Vargas-Villafuerte, J., & Cuevas-Calderón, E. (2022). Neoliberalización de la gestión urbana en Lima Metropolitana, Perú. *Revista Invi*, 37(105), 72-97. <https://doi.org/10.5354/0718-8358.2022.65453>
- Wehle-Strzelecka, S. (2014). Close-to nature housing – Austrian examples. *Technical transaction Architecture*, 3-A(3), 147-160.
- Wieser, M. (2014). The 'Teatinas' of Lima: Energy analysis and possibilities of contemporary use. In R. Rawal, S. Manu, & N. Khadpekar (Eds.), *30th International PLEA Conference: Sustainable Habitat for Developing Societies: Choosing the Way Forward - Proceedings* (pp. 263-270). CEPT University Press.
- Young, J. (2015). *Towards zero energy buildings: lessons learned from the BedZED development*. [Doctoral dissertation]. University College London]. UCL discovery. <https://discovery.ucl.ac.uk/id/eprint/1472436/>
- Zalamea-León, E., & Quesada, F. (2017). Criterios de integración de energía solar activa en arquitectura. *Revista de Arquitectura*, 19(1), 56-69. <http://dx.doi.org/10.14718/RevArq.2017191.1018>

